

# DOWNHOLE, ABSOLUTE, PRESSURE TRANSDUCERS



The 211-37-520 transducer is designed for applications requiring long term stability at high temperatures up to **+400°F (+204°C)** in corrosive environments. Features such as wide range of pressure options, a small size and rugged design, hermetically sealed all welded construction, fully calibrated and environmentally tested are just a few of the 211-37-520 benefits.

The Inconel 718®™ material used in construction is compatible with H2S and other highly corrosive media. Instead of an O-ring, a replaceable Inconel 600 seal can be used for virtually maintenance-free, permanent installations.



**211-37-520-XX\***  
0-5,000 to 0-30,000 PSIA

### Specifications:

**Typical Performance:** The following parameters are established from production units.

**Calibration Data:** Calibration Certificates are supplied with each unit.

### Performance: \*

**Non-Linearity and Hysteresis Combined:**  $\pm 0.15\%$  of Full Scale Output (F.S.O.) maximum. (Best Straight Line Method)

**Total Error Band Including Non-Linearity, Hysteresis and Thermal Effects:**  $\pm .75\%$  F.S.

**Operating Temperature Range:**  $-40^{\circ}\text{F}$  to  $+400^{\circ}\text{F}$  ( $-40^{\circ}\text{C}$  to  $+204^{\circ}\text{C}$ ).

**Compensated Temperature Range:**  $+75^{\circ}\text{F}$  to  $+350^{\circ}\text{F}$  ( $+23^{\circ}\text{C}$  to  $+176^{\circ}\text{C}$ ).

### Mechanical: \*

**Pressure Range:** 0-5,000 to 0-30,000 PSIA.

**Proof Pressure:** 125% to 150% of rated range (depending on part option).

**Burst Pressure:** 150%, 200% to 40,000 PSI of rated range (depending on part option).

**Pressure Media:** Any compatible with alloy UNS N07718 Rockwell C 40 maximum.

**Environmental:** Error due to combined effect of shock, vibration and acceleration shall be less than 0.01% of F.S.O. per G, 20G maximum.

**External Case Pressure:** Up to 20,000 PSI.

**Electrical Connections:** High temperature solderable connections.

**Pressure Port:** Per MS33656-E3.

**Weight:** 2.0 ounces nominal (.056 kg).

**Installation Information:** Manifold mount on port using Paine Electronics annealed Inconel 600 replaceable seal. Thermal coefficient of the manifold expansion should not exceed  $8.3 \times 10^{-6}$  in/in  $^{\circ}\text{F}$  for operation above  $100^{\circ}\text{C}$ .

**Recommended Installation Torque:** 125 to 150 in-lb (14-17 Nm).

### Electrical: \*

**Excitation:** 1 to 20 VDC (10 VDC nominal).

**Input Resistance:**  $1500 \pm 300 \Omega$ .

**Output Resistance:**  $1500 \pm 150 \Omega$ .

**Output at Zero Pressure:**  $0 \pm 2.0\%$  F.S.O.

**Full scale (F.S.) Sensitivity:**  $2.6 \text{ mV/V} \pm 0.2\%$ .

**Insulation Resistance:** All conductors together to case,  $10\text{G}\Omega$  minimum at 50 VDC and  $+77^{\circ}\text{F}$ .

**Platinum Resistance Temperature Detector (RTD):**  $0^{\circ}\text{C}$ ,  $1000 \Omega \pm .06\% \Omega$ .

to IEC 751, Class A, Alpha = .00385 nominal.

**Electrical Connections:** A= + Excitation, B= + Signal, C= - Signal, D= - Excitation, E= RTD, F= RTD.

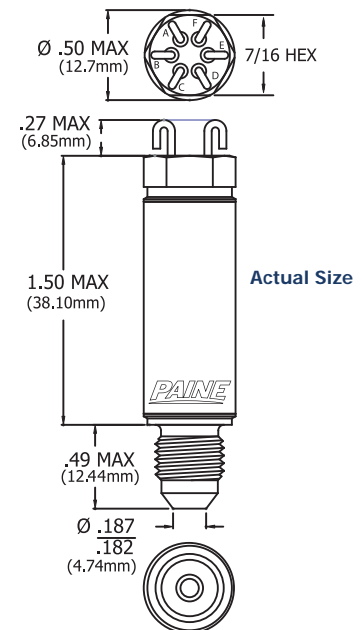

Actual Size



Paine Electronics, LLC is a proud ISO-9001/AS9100 registered company

Datasheet P/N: 211-37-520-DS\_REV-E

\* Contact us or your authorized Paine Electronics representative for other standard and/or custom configurations or options.

Call or email us today for more information!

# 509-881-2100

moreinfo@paineelectronics.com

**Paine Electronics, LLC**  
5545 Nelpar Drive, East Wenatchee WA 98802  
Tel: (509) 881-2100 | Fax: (509) 881-2115

Visit us on the web at:  
[www.paineelectronics.com](http://www.paineelectronics.com)