



## 212-60-090 SERIES, AMPLIFIED, DIFFERENTIAL PRESSURE TRANSDUCER



212-60-090-XX  
0-500 to 0-5,000 PSID

The **212-60-090 amplified output**, full line differential pressure transducer features built-in electronics eliminating the need for separate transducers and amplifier units. It is **temperature compensated** and provides input/output isolation for trouble free circuit interface, input reverse polarity protection, output short circuit protection and long term stability at temperatures from **-40°F to +250°F** (-40°C to +121°C) in pressure ranges of **0-500 to 0-5,000 PSID**.

Designed for dependable, **Industrial, Marine and Aerospace** applications such as armored vehicle hydraulic controls and actuators, propulsion and fuel pressure monitoring, aviation engine testing and in many general purpose differential pressure measurements. The **212-60-090** is offered in a manifold style mounting package and can be supplied with optional mounting and/or pressure adapters for increased flexibility, positioning and location.

### Specifications:

**Typical Performance:** The following parameters are established from production units.

**Calibration Data:** Calibration Certificates are supplied with each unit.

### Performance: \*

**Thermal Zero Shift:**  $\pm 0.01\%$  of Full Scale Output (F.S.O.) per °F maximum.

**Thermal Sensitivity Shift:**  $\pm 0.01\%$  of F.S.O. per °F maximum.

**Static Error Band Including Non-Linearity and Hysteresis Combined:**  $\pm 0.5\%$  F.S.O. (Best Straight Line Method) each port separately.

**Operating Temperature Range:** -40°F to +250°F (-40°C to +121°C).

**Compensated Temperature Range:** -25°F to +250°F (-31°C to +121°C).

### Mechanical: \*

**Pressure Range:** 0-500 to 0-5,000 PSID.

**Proof Pressure:** 150% of rated range (line and differential).

**Burst Pressure:** 250% of rated range (line and differential).

**Pressure Media:** Any compatible with 304 series, 15-5 PH CRES and Buna-N-Rubber.

**Electrical Connections:** 6 pin bayonet connector. Mates with M83723-75R-10066.

**Pressure Port:** Available with manifold mounting per MIL-P-5514, Type II, Class 2 Recommended O-rings MS28775-008 are supplied with the transducer.

**Weight:** 6.0 ounces maximum (0.170 kg).

**Environmental:** Error due to combined effect of shock, vibration, and acceleration shall be less than 0.02% of F.S. per G.

### Electrical: \*

**Excitation:** 9 to 40 VDC.

**Excitation Current:** 17 mA maximum at 20 VDC excitation.

**Performance Characteristic Values:** Apply only for load impedance values of 50,000  $\Omega$  minimum.

**Input/Output Isolation:** 100 M $\Omega$  minimum at 50 VDC.

**Output at Zero Differential Pressure:**  $0.0 \pm 0.10$  VDC =  $E_0$

**Output at Positive Rated Pressure (P1>P2):**  $+5.0 \pm 0.10$  VDC =  $E_p$

**Output at Negative Rated Pressure (P2>P1):**  $-(E_p - 2E_0) \pm 0.10$  VDC

**Electrical Connections:** 1= Excitation Input, 2= Output (+ IF P1>P2),

3= Output Return, 4= Excitation Return, 5= Not Used, 6= Not Used

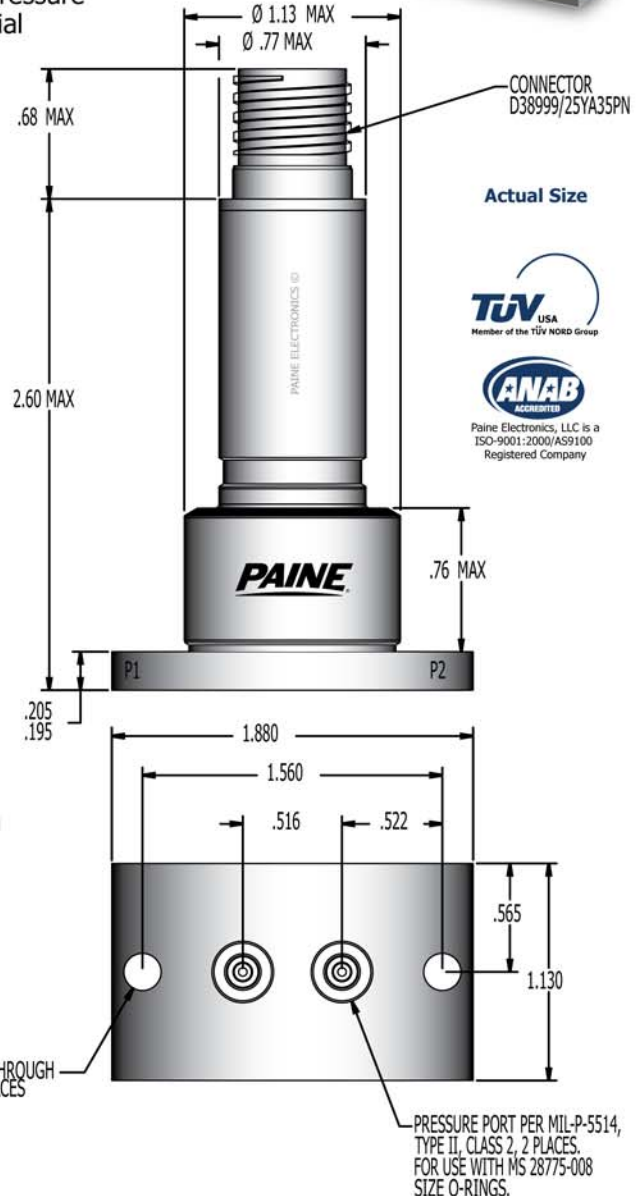

Datasheet P/N: 212-60-090-DS\_REV-C

\* Contact us or your authorized Paine Electronics representative for many more standard and/or custom configurations or options.

All specifications are subject to change or modification without notice. P A I N E ® is a registered trademark of Paine Electronics, LLC. Copyright © Paine Electronics, LLC | All Rights Reserved

Call or email us today for more information!

**509-881-2100**  
moreinfo@paineelectronics.com

**Paine Electronics, LLC**  
5545 Nelpar Drive, East Wenatchee WA 98802  
Tel: (509) 881-2100 | Fax: (509) 881-2115

Visit us on the web at:  
[www.paineelectronics.com](http://www.paineelectronics.com)